

Dual brakes
mechanical ratchet pawls and motor dynamic brake provide slip free operation

Friction clutch
Safety slipping clutch prevent hook becoming trapped into the hoist in the "up" direction

Aluminum die cast housing
Tough and durable

Durable canvas container as standard

Push button switch
fitted with an emergency stop button as standard

360° bottom hook
Fitted with a self-locking latch with bearing for free swiveling

Permanent magnetic motor
Features constant output and low noise level

Cutoff switch
Power cutoff switch prevent the overloading of the hoist

House power supply
Operate on standard domestic power supply and equip with industrial plug

PACKAGE:

- Hoist weight: 19.3 kg
- Gross weight: 27 kg for CK-500
32 kg for CK-1000
- Box dimension: 380 x 410 x 345 mm

STANDARD ACCESSORIES:

- Load chain Grade 80
- Remote control w/emergency stop w/1.25 mm² x 6C x 3 m cord
- Industrial plug w/1.5 mm² x 3C x 3 m
- CK-500: hook tackle : CK-1000: hook block
- Hook suspension
- Chain bag
- Power cutoff switch

Warranty:

Each new hoist is guaranteed against defects in workmanship and material defects for a period of twelve months from date of purchase. Chain are not included under warranty

Warning:

- The hoist is not intended to be used in any manner for the movement or lifting of personnel.
- The fixing point for baby hoist shall be capable of supporting the load required.



- Permanent magnetic motor features constant output and low noise level.
- Lightweight and compact designs are ideal for easy installation.
- Dual brakes for double mechanical ratchet pawls and a motor dynamic brake provide slip free operation.
- Safety slipping clutch prevents hook becoming trapped into the hoist in the "up" direction
- Power cutoff switch prevent the overloading of the hoist
- Tough aluminum die cast housing provides massive structural durability.
- Can operate on standard domestic power supply and equip with industrial plug
- A switch w/emergency stop comes as standard
- A 360° bottom hook fitted with a self-locking latch has a bearing is capable of swiveling with the safe working load applied
- Standard Compliance: CE Machinery Directive 2006/42/EC, CE EMC Directive 2004/108/EC, EN 14492-2 Power Driven hoists 2006, JIS B8815, ISO 4301-1 and ASME B30.7

SPECIFICATIONS:

Model	CK-500	CK-1000
Duty Cycle	25% ED at 63% of rated load	
Drive Group	FEM: 9,511 1Bm, ISO: 4301-1 M3	
Voltage	100 – 120V, 200 – 240V AC, single phase	
Lifting Load	500 kg	1,000 kg
Lifting Height	3 m 6 m	3 m 6 m
Type of Fall	Single	Double
Motor Output	100 – 120 V / 750w, 9.5A permanent magnetic 200 – 240 V / 750w, 4.5A permanent magnetic	
Line Speed	6.5 m/min	3.2 m/min
Brake	Dual brakes of double mechanical ratchet pawls and motor dynamic brake	
Gear Ratio	70.2 :1	
Load Chain	Grade 80– Links 6.3 mm dia. x 19 mm long	

* The lifting height shown is the maximum using the standard chain storage bag. For further options are also available upon request

DIMENSION:mm/in

CK-500

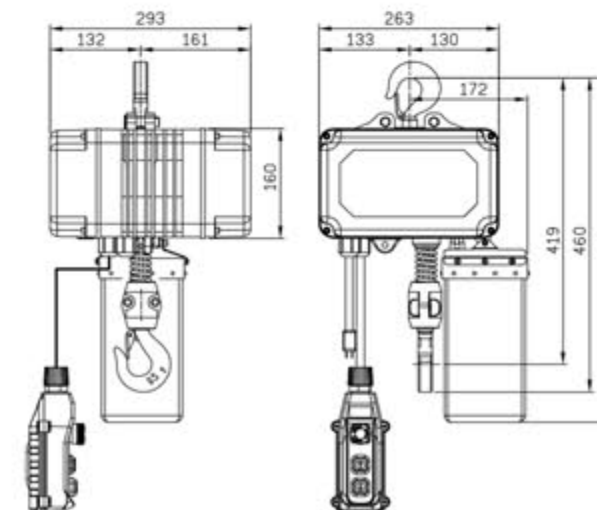

CK-1000

