

# COMEUP

Dual Speed



## Brushless DC Motor Chain Hoist BMC-500/1000

### Features Include

- Brushless motor generates no carbon dust or sparks, and has long lifespan.
- Excellent energy-saving efficiency using DC variable frequency control, which provides low startup and rated current, and ensures smooth operation.
- Emergency stop pendant switch has two-stage, dual-speed control. At low speeds, rotary knob provides precise alignment/feeding, ideal for precision-first industries, e.g. precision-molding, vertical carrying in logistics.
- Equipped with 6 major safety features:
  1. Auto power-off on motor overheating.
  2. Auto power-off for crane overload.
  3. Auto power-off for abnormal input voltage (too high /too low).
  4. Auto power-off for motor stall.
  5. Safety torque limiter to prevent hook from getting stuck.
  6. Upper and lower limit switches to prevent chain over-wrapping
- Brake System driven by motor dynamic brake, paired with mechanical ratchet pawls for maximum safety
- IP55 rating.
- Aluminum alloy housing provides durability to overall structure.
- Comes with an industrial-grade plug, which can be directly inserted into a single-phase 200-240V power.
- Standard Compliance: CE Machinery Directive 2006/42/EC, CE EMC Directive 2014/30/EU, EN 14492-2 Power Driven hoists 2006, JIS B8815, ISO 4301-1 and ASME B30.7.

### Standard Accessories

- Load chain Grade FC80
- Remote control w/emergency stop w/0.5 mm<sup>2</sup> x 7C x 3 m cord
- Industrial plug w/1.5 mm<sup>2</sup> x 3C x 3 m
- BMC-500: hook tackle; BMC-1000: hook block
- Hook suspension
- Chain bag

### Package

- Hoistweight : 19.3kg
- Gross weight : 27kg for BMC-500  
32kg for BMC-1000
- Box dimension : 380 x 410 x 345 mm

### Warning

- The hoist is not intended to be used in any manner for the movement or lifting of personnel.
- The fixing point for baby hoist shall be capable of supporting the load required.

### Warranty

Each new hoist is guaranteed against defects in workmanship and material defects for a period of twelve months from date of purchase. Chain are not included under warranty

### Specifications

Model	BMC-500	BMC-1000
Duty Cycle	25% ED at 63% of rated load	
Drive Group	FEM: 9,511 1BM, ISO: 4301-1 M3	
Power	AC200 – 240V 50/60Hz , single phase	
Lifting Load	500 kg	1,000 kg
Lifting Height	3 m	3 m
Type of Fall	Single	Double
Motor Output	500w, 6.6A Brushless DC motor	
Line Speed (220V 60Hz)	0.2~1.8 / 6.5 m/min	0.1~0.9 / 3.2 m/min
Brake	Dual brakes of motor dynamic brake, paired with mechanical ratchet pawls	
Gear Ratio	70.2 : 1	
Load Chain	Grade FC80– Links 6.3 mm dia. x 19 mm long	

The lifting height shown is the maximum using the standard chain storage bag. For further options are also available upon request

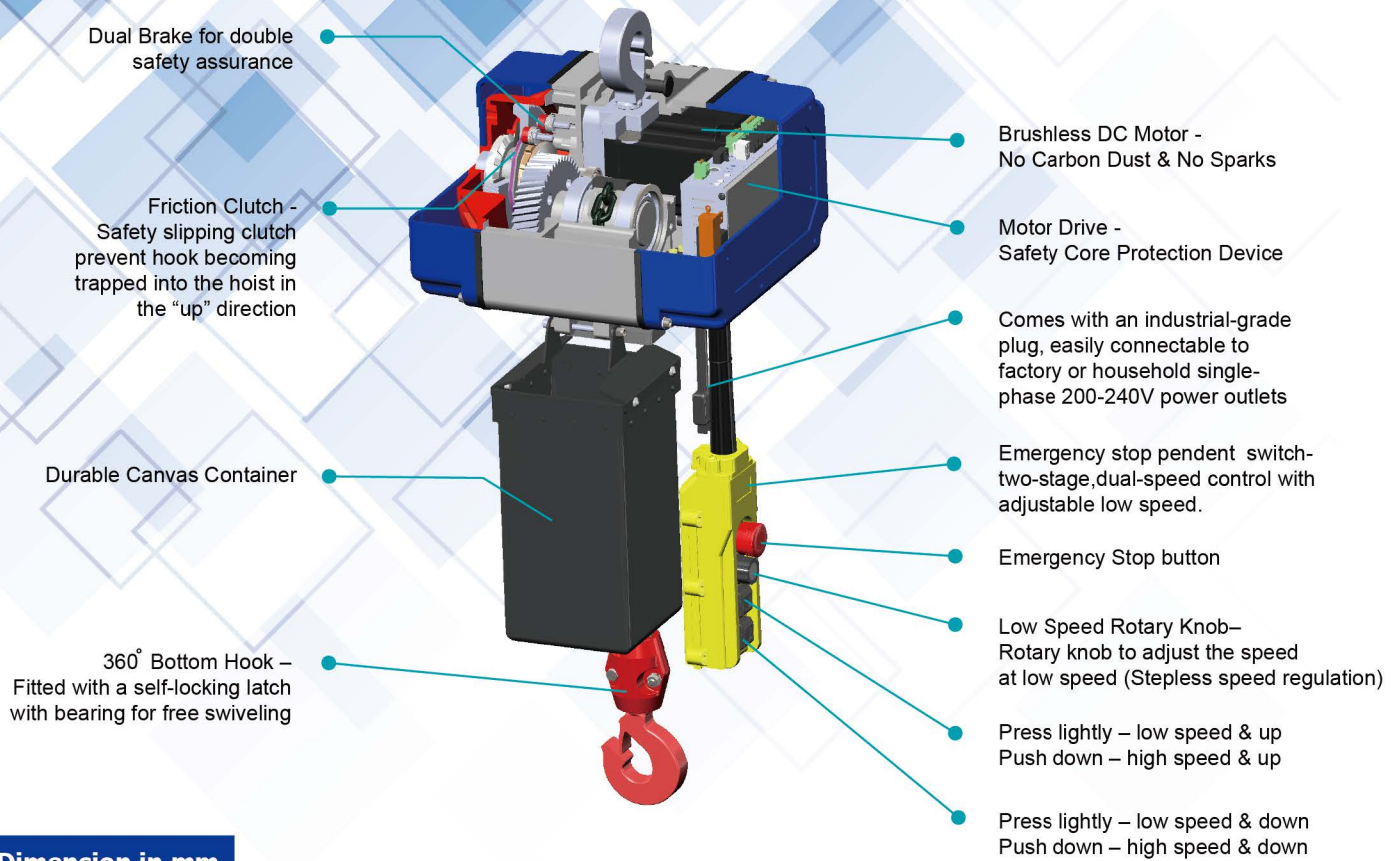

## Dimension in mm

**BMC-500**

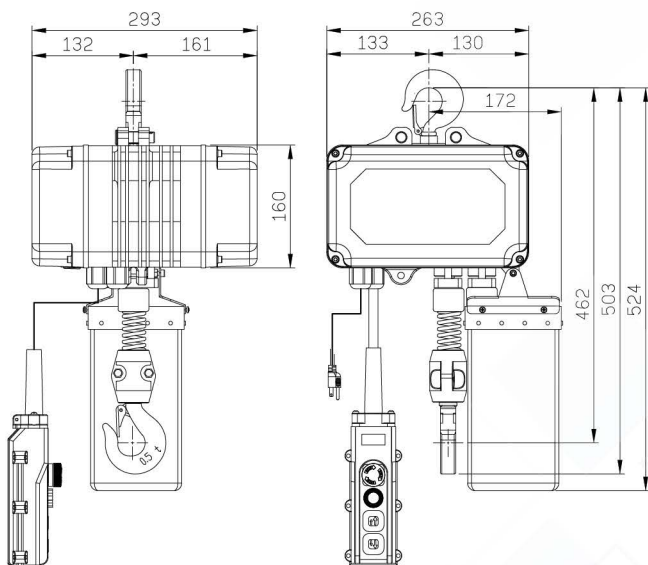

**BMC-1000**

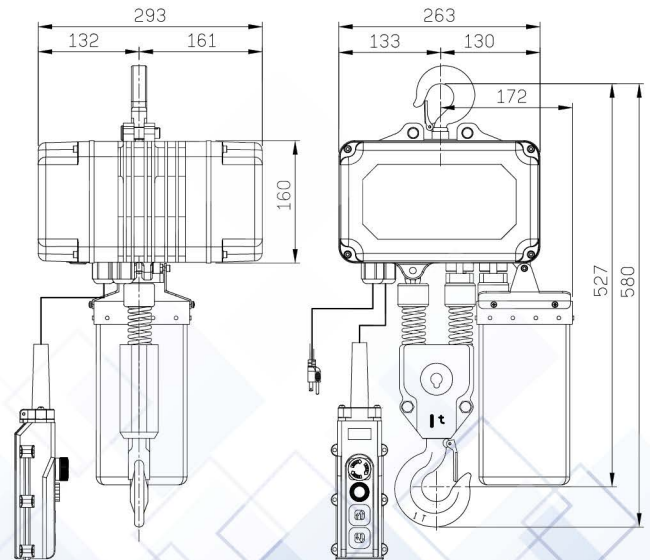

# COMEUP

**COMEUP INDUSTRIES INC.**

No.139, Jieyukeng Rd., Ruifang Dist., New Taipei City 22453, Taiwan

Tel :+886-2-24971788

Fax:+886-2-24971699

E-mail:info@comeup.com.tw

<https://www.comeupwinch.com>

<https://www.facebook.com/COMEUP>



Distributed By

